

'e' CLIP



The 'e' series clip with its unique geometric design offers a lightweight, low cost rail fastening. Spring and torsion work together to provide a high clamping force, excellent resistance to rail rollover and longitudinal restraint.

The 'e' clip is driven parallel to the rail and is easily installed, manually with standard track tools, or with mechanical equipment.

 **PANDROL**

TRACK SYSTEMS

© DELACHAUX GROUP

SPECIFICATIONS:

- Made from high spring steel alloy
- Bar Diameter: 20mm
- Approximate Shipping Weight: 1.7 lbs.
- Normally packed 25 per bag
- P/N ECL-2055 (right hand)
- P/N ECL-2056 (left hand)
- P/N ECL-2009L (Canada)

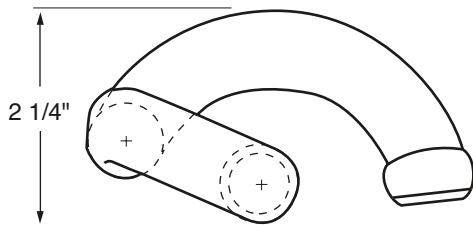

The 'e' clip design utilizes the toe to bear on the rail base. The toe is flattened to provide a large bearing area on the rail or insulator.

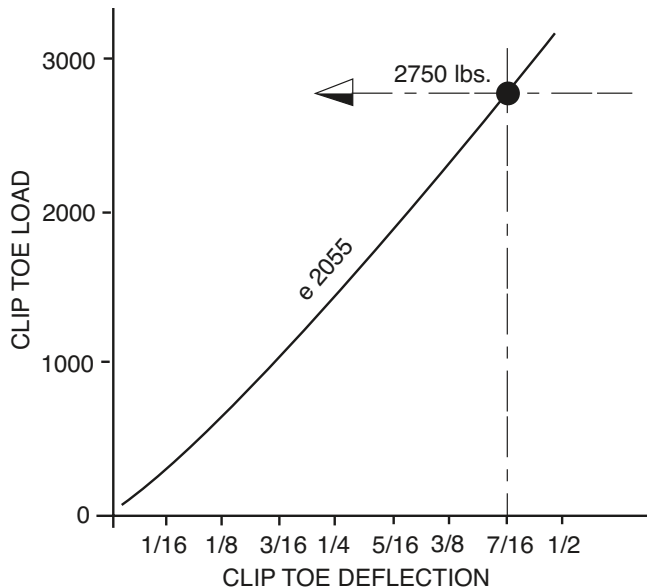

Clip	'e' 2055
Bar Diameter	20 mm
Nominal Toe Load	2,750 lbs
Working Deflection	7/16"
Nominal Rail Seat	
Clamping Force	5,500 lbs
Surface area in contact with insulator or rail	.82 sq. in.

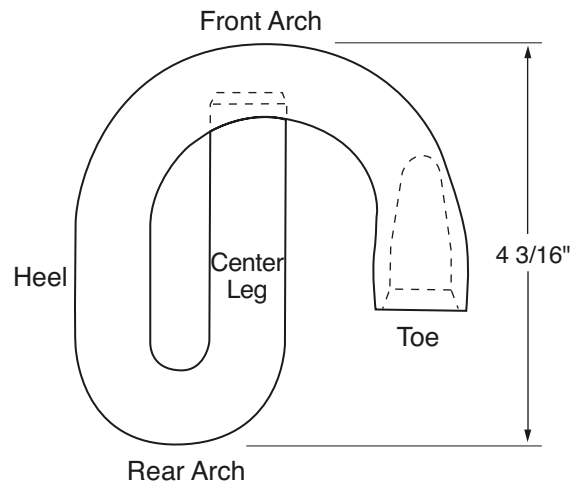

Chamfered center leg allows easy setting and driving.



© DELACHAUX GROUP



Learn More >

Pandrol USA, LP
 501 Sharptown Road
 P.O. Box 367
 Bridgeport, NJ 08014
 (856) 467-3227
 (800) 221-CLIP

www.pandrolusa.com

